

**FOR A CENTURY, PRIDE OF THE FARM HAS
DELIVERED WATER IN RELIABLE, RUGGED DRINKERS**

**TODAY WE HAVE OVER 30 OPTIONS TO DO IT
NO ENERGY COST.....OR.....LOW ENERGY COST**

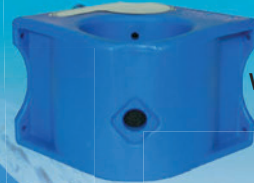

MBH5B



WPO1BE



WPM14A



WPO12E



WPM10



WPO25E



WPM20

**FOR YOU. FOR YOUR FARM.
FOR A CENTURY.**



WPM120



WPO50N



WPO70N

Industry's Best Warranty!

- All Poly Main Components
5 Years Unconditional Warranty
- And An Additional 11 Year
Pro-Rated Warranty
- Valve & Heater - 18 Month
Unconditional Warranty

Six generations have known, if you want to buy it once.....buy Pride of the Farm®



Pride of the Farm®
watered field hands
in 1923!



In 1979, Pride of the Farm became the
first animal drinker manufacturer to use
polyurethane foam insulation.



Our first Polar-Max® 100%
Energy Free Drinker was
introduced in 1988.



In 1999, Pride of the Farm®
introduced Performance One
E-Drinkers, our series of energy
efficient, electrically heated drinkers.

WHY PRIDE OF THE FARM?.....TEN REASONS

1. Our valves and flow rates, our designs, our quality are all directed toward job number one-WATER. Delivered efficiently and hassle free.

2. On most models, we double protect the valve. FOUR sided insulated baffle walls plus the drinker base wall.

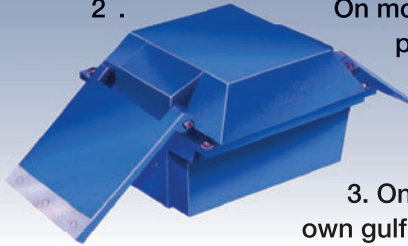

3. On heated models we set our own gulf stream into motion with patented water circulation holes in the valve cover.

4. Grade A dairy compliant.

5. Service. We work with you on unusual applications. We help you solve your problems.

6. We establish standards for foam voids and test against those



standards to give the best freeze protection.

7. We use the best stabilizers for UV protection-both for mechanical properties and for color fastness.

8. Either LOW cost or NO cost. With our heated drinkers, ANNUAL costs will be in the \$10 to \$25 range.

Compared with concrete drinkers, our electrical costs are a fraction.

9. Attention to detail. Example: molded in brass inserts – no fasteners directly into the plastic.

10. Longevity.

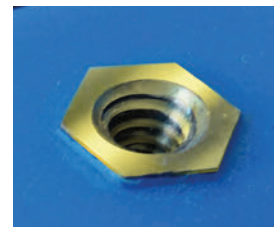

One of our largest distributors said this, "The top challenge I have selling Pride of the Farm is that your customers know your drinkers will last 30 years or more. They say – why buy a new drinker when the ones they have are probably good to go for another 30."

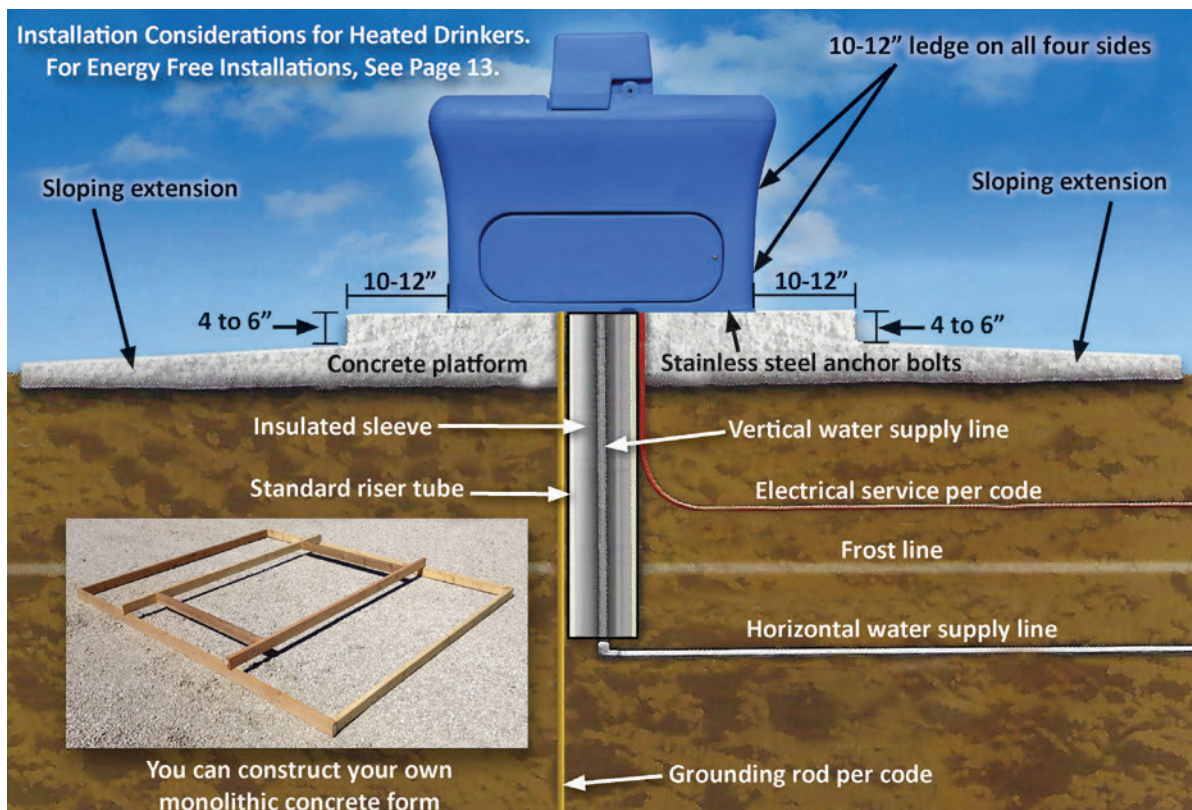

THE RACE IS OVER..... OUR PERFORMANCE ONE BOX STALL DRINKER WINS BY SEVERAL LENGTHS

FOR CORNER INSTALLATIONS IN BOX STALLS—
BUT CAN BE INSTALLED OUTDOORS AS WELL

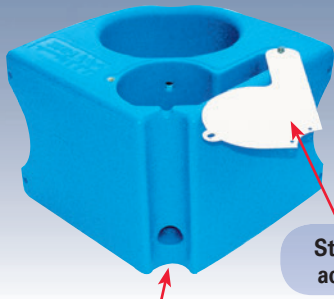

Stainless steel access plates.

1/4 moon design on back corner for securing up to a 2" (5.1 cm) PVC tube for plumbing from above or below.

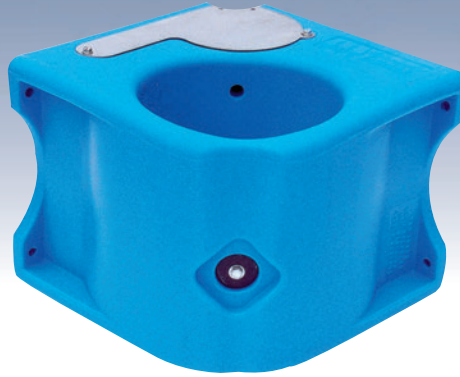

Foam filled--R value of 7.5 per inch.

Double wall, single piece poly construction--ALL SMOOTH!

VT100 Valve Series handles a wide range of water pressures. Simple water level adjustment, easy to clean.

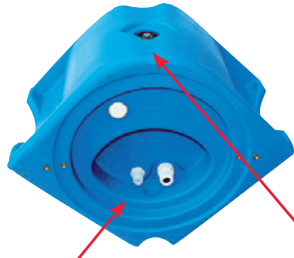
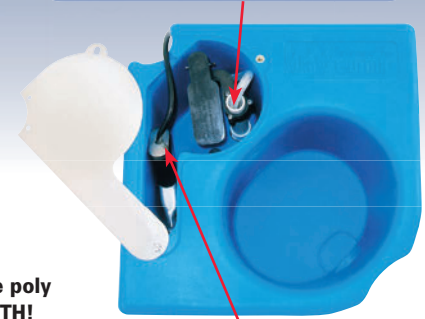

Internal 3/4" (1.9 cm) AND external 2" (5.1 cm) drains; drinker is very easy to clean--no disassembly for cleaning required.



We've been watering animals since 1903!

Optional heater, 250 watts, 110 volts. We tested this unit in a cold chamber at minus 30° F (-34.4° C). No freezing occurred at this temperature -- even after 7 days!

Heating cost is minimal--less than \$10.00 per heating season.

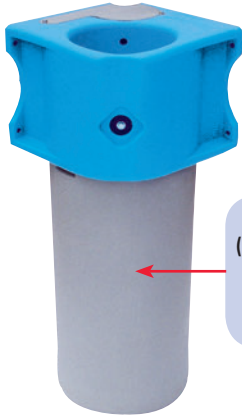

Optional ground mount tube (Model HT10) for hookup to underground service connections and for outdoor installations. Available in light gray only.



*Available in blue or red.

Industry's Best Warranty!

- All Poly Main Components 5 Years Unconditional Warranty
- And An Additional 11 Year Pro-Rated Warranty
- Valve & Heater - 18 Month Unconditional Warranty

USA Patent Number D480,516
USA Patent Number 6,722,313 B2

Specifications

| PRODUCT | APPROXIMATE CAPACITY | | | SIZE INCHES (cm) | | | | VALVE | HEATER ELECTRIC | SHIPPING WEIGHT Lbs (kg) |
|-------------------|--|---------|--------|-------------------------|---------------|----------------|----------------|-------|--------------------|-------------------------------------|
| | ANIMALS | WATER | | DRINK OPENING | OVERALL WIDTH | OVERALL LENGTH | OVERALL HEIGHT | | | |
| | | GALLONS | LITERS | | | | | | | |
| BOX STALL DRINKER | 1 horse in a box stall or 15 head of most any species except swine | 1.5 | 5.7 | 8-1/2 x 9 (21.6 x 22.9) | 15-1/2 (39.4) | 15-1/2 (39.4) | 12 (30.5) | VT100 | 250 Watts Optional | 17 (7.7) Heated 15 (6.8) No Heat |

*Model Numbers: WPO1BE-Heated, Blue Color; WPO1BN-No Heat, Blue; WPO1RE-Heated, Red; WPO1RN-No Heat, Red. All models shippable via UPS.



AS VERSATILE AS YOU CAN GET.....

WATER HORSES, CALVES, WILDLIFE WITH PERFORMANCE ONE MODEL WPO6... FOR STALLS, CORRALS AND PADDOCKS

VT100 Valve Series handles a wide range of water pressures. Simple water level adjustment, easy to clean.



Double wall, single piece poly construction--ALL SMOOTH!

Foam filled insulation--R value of 7.5 per inch which offers lots of freeze protection.

Optional heater, 250 watts, 110 volts. We tested this unit in a cold chamber at minus 30° F (-34.4°C). No freezing occurred at this temperature – even after 7 days!

Heating cost is minimal—less than \$10.00 per heating season.

Easy access to valve and heater -- just lift stainless steel access plate.

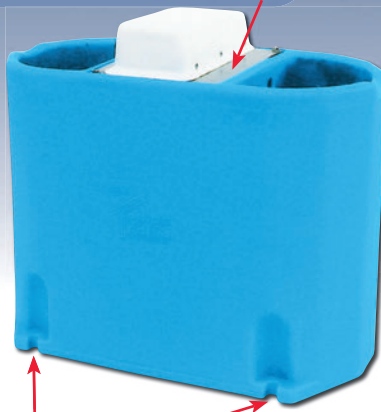

Four recessed anchor notches for secure installation.

Drinker is very easy to clean--no disassembly for cleaning required.



Large 2" (5.1 cm) external and internal clean out drains

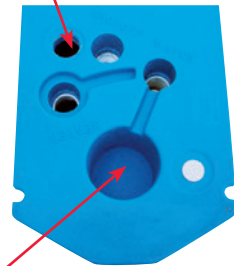

Cavity for warm climate installations only. Some warm geographic areas do not use a riser tile and may only have a buried supply line protruding through a concrete pad. The cavity can be used to make the connection from the supply line to our valve.

Industry's Best Warranty!

- All Poly Main Components 5 Years Unconditional Warranty
- And An Additional 11 Year Pro-Rated Warranty
- Valve & Heater - 18 Month Unconditional Warranty

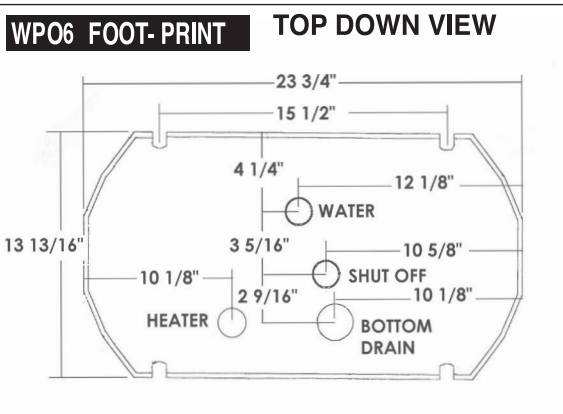

We've been watering animals since 1903!

Specifications

USA Patent Number 6,722,313 B2

| MODEL | APPROXIMATE CAPACITY | | SIZE INCHES (cm) | | | | VALVE | HEATER ELECTRIC | SHIPPING WEIGHT Lbs (kg) | |
|-------|---|---------|------------------|-----------------------------|--------------------|------------------|------------------|-----------------|--------------------------|-----------------|
| | ANIMALS | WATER | | DRINK OPENINGS | OVERALL WIDTH | OVERALL LENGTH | | | | OVERALL HEIGHT* |
| | | GALLONS | LITERS | | | | | | | |
| WPO6E | 25 Horses 40 Ponies 100 Calves 40 Cattle | 6 | 22.7 | 6-1/2 x 10 (16.5 x 25.4) | 13-13/16 (35.1) | 23-3/4 (60.3) | 21-1/2 (54.6) | VT100 | 250 Watts | 25 (11.4) |
| WPO6N | 25 Horses 40 Ponies 100 Calves 40 Cattle | 6 | 22.7 | 6-1/2 x 10 (16.5 x 25.4) | 13-13/16 (35.1) | 23-3/4 (60.3) | 21-1/2 (54.6) | VT100 | None | 21 (9.5) |

*Drinking Height 18"

All models shippable via UPS.



PERFORMANCE ONE — ENERGY EFFICIENCY WITH CAPACITY

SUPERB ENERGY EFFICIENCY FOR NEW INSTALLATIONS YOU ONLY NEED ONE UNIT FOR UP TO 150 HEAD

A typical winter heating bill—\$10.00 or less! Why? Two reasons. Our drinker has 17 gallons of capacity. Incoming water carries heat energy. The more water, the more heat. Our R-value of 7.5 per inch holds the heat provided by incoming water. Secondly, our supply line is in the water. You don't need extra heat to keep the line above the ground open. You do need proper installation to prevent the supply line underneath the drinker from freezing.

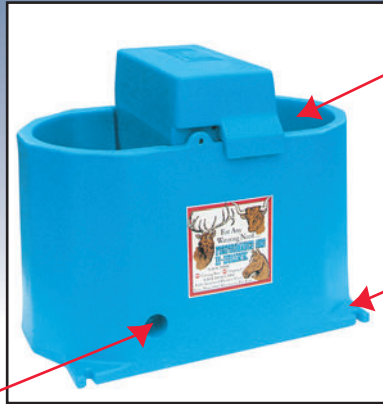

2 large drink openings 8" x 14" each. Drinker wells are 14" deep allowing most animals to drink naturally.

100% poly construction. Molded with the most effective ultraviolet inhibitor. Tough enough for years of outdoor use.

Notched flanges for easy anchoring.

Over 300 square inches of access for easy hook up.

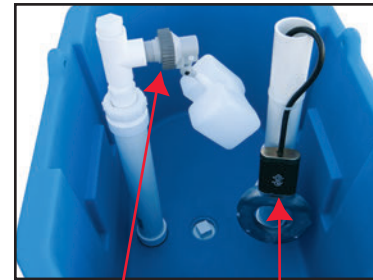

Dependable non-siphoning Durapride valve (40 years of use)

PROVEN (30 years of use) 250 watt heater

Two-2" side drains and 1 threaded bottom port for optional inside drain.

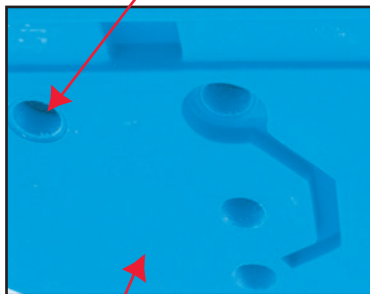

Sealed bottom keeps out moisture and rodents.



Stainless steel spring loaded valve cover removes easily.

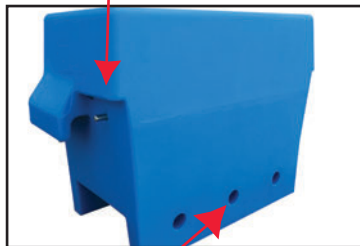

Patented discharges in side of cover facilitate heat movement into drink openings.

Industry's Best Warranty!

- All Poly Main Components 5 Years Unconditional Warranty
- And An Additional 11 Year Pro-Rated Warranty
- Valve & Heater - 18 Month Unconditional Warranty

WPO17 FOOT-PRINT TOP DOWN VIEW

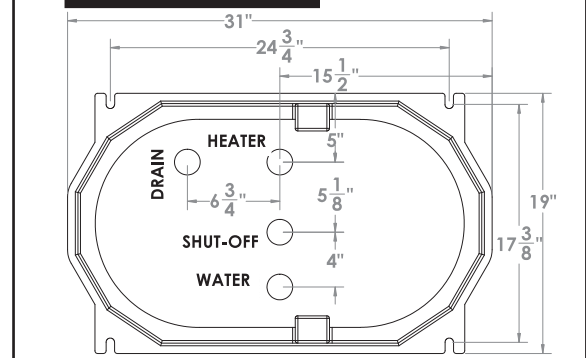

Specifications

| MODEL NUMBER | APPROXIMATE CAPACITY | SIZE INCHES (CM) | | | | | | | HEATER ELECTRIC | SHIPPING WEIGHT LBS (KG) |
|--------------|---|------------------|--------|----------------------------|-------------------|--------------|----------------|----------------|-----------------|--------------------------|
| | | ANIMALS | WATER | | DRINK OPENING | DRINK HEIGHT | OVERALL WIDTH | OVERALL LENGTH | | |
| | | GALLONS | LITERS | | | | | | | |
| WPO17E | 150 head of most any species except swine | 17 | 64.3 | 8 1/2" x 14" (21.6 x 35.6) | 17 3/4" (45.1 cm) | 19" (48.3) | 29 1/2" (74.9) | 23" (58.4) | 250 watts | 40 (18.2) |
| WPO17N | 150 head of most any species except swine | 17 | 64.3 | 8 1/2" x 14" (21.6 x 35.6) | 17 3/4" (45.1 cm) | 19" (48.3) | 29 1/2" (74.9) | 23" (58.4) | none | 37 (16.8) |

Shippable via UPS

USA Patent Number 6,722,313 B2



THE KNIGHT PERFORMANCE ONE WITH LOWER ACCESS

**ENERGY EFFICIENT HANDSOME PERFECT FOR EXISTING
DRINKER REPLACEMENT OR FOR NEW INSTALLATIONS**



Checkmate! Great value and great features don't have to come in a boring, boxy profile. Model WPO12 is loaded and is also one of the better looking drinkers ever to reach the market.

Stainless steel spring loaded valve cover removes easily and is easily re-installed.



Dependable, non-siphoning Durapride valve (50 years of use)

2" built-in drain

Proven (30 years of use) 250 watt heater



Overflow port can be used either as an internal drain or it can be used for optional continuous flow operation.

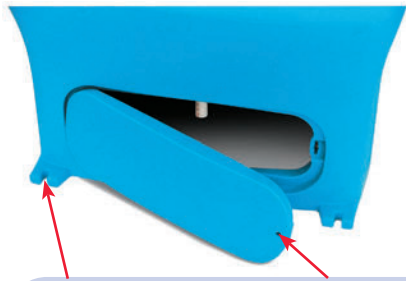

Rugged notches for secure anchoring. Spring loaded pin allows easy removal of access panel. It takes a quarter turn with a straight edge screwdriver. Lower access opening is 6" x 19".

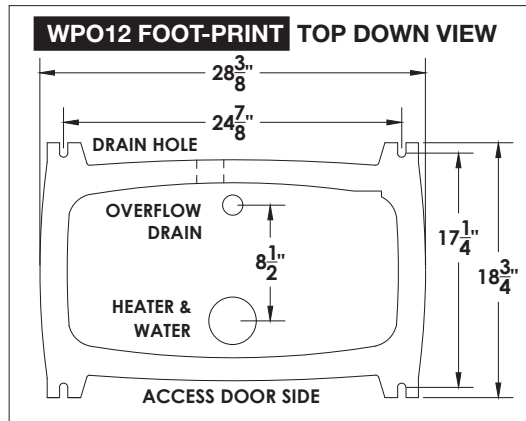

Industry's Best Warranty!

- All Poly Main Components
5 Years Unconditional Warranty
- And An Additional 11 Year
Pro-Rated Warranty
- Valve & Heater - 18 Month
Unconditional Warranty

Specifications

| MODEL NUMBER | APPROXIMATE CAPACITY | | SIZE INCHES (CM) | | | | | | HEATER ELECTRIC | SHIPPING WEIGHT LBS (KG) |
|--------------|---|--------|------------------|------------------------|---------------|----------------|----------------|----------------|-----------------|--------------------------|
| | ANIMALS | WATER | DRINK OPENING | DRINK HEIGHT | OVERALL WIDTH | OVERALL LENGTH | OVERALL HEIGHT | | | |
| | GALLONS | LITERS | | | | | | | | |
| WPO12E | 150 head of most any species except swine | 12 | 45.4 | 9" x 15" (22.9 x 38.1) | 20" (50.8) | 19" (48.3) | 31" (78.7) | 25 1/2" (64.8) | 250 watts | 43 (19.5) |
| WPO12N | 150 head of most any species except swine | 12 | 45.4 | 9" x 15" (22.9 x 38.1) | 20" (50.8) | 19" (48.3) | 31" (78.7) | 25 1/2" (64.8) | none | 41 (18.6) |

Shippable via UPS

USA Patent Number 6,722,313 B2



SMALL RUMINANT DRINKERS

WE HAVE SEVERAL DRINKERS THAT WORK GREAT WITH SMALL RUMINANTS.

We suggest the ones shown below. Both Polar-Max 100% energy free drinkers and Performance One heated drinkers work very well for sheep, goats and other animals.



WPO6E
See page 4



WPM10A
See page 14 & 18



WPM14A
See page 14 & 18

KRIT-R KANTEEN™

NOW THERE'S A BETTER WAY TO PACK WATER.

OUR CANTEEN FITS COMPACTLY IN THE CORNER OF YOUR TRAILER OR TACK ROOM. TAKE IT TO THE FAIR — ANIMALS MORE READILY DRINK THE WATER TO WHICH THEY ARE ACCUSTOMED.



Lower shutoff with garden hose thread.



Vented top fill cap.

30 gallon capacity

Markers every 5 gallons are easily read through our translucent material

FDA approved poly with ultraviolet inhibitors



1" x 60" nylon strap with double ring buckle. Secure tank against a fence or the side or nose of your trailer.



Store your hose in the 6" x 8" opening of the optional base (hose not included).



Specifications

| MODEL NUMBER | DIMENSIONS IN INCHES | | | SHIPPING WEIGHT |
|---|----------------------|--------|--------------------------|-----------------|
| | CAPACITY | HEIGHT | GIRTH | |
| WCN30 Canteen | 30 Gal. | 54 3/4 | 16 1/4 x 16 1/4 x 16 3/4 | 20 Lbs |
| WBE30 Base | | 12 1/2 | 17 1/2 x 17 1/2 x 18 | 6 |
| When the canteen is placed in the base, the height is | | 65 3/4 | | 26 |

Shippable via UPS

